

SCRIGNO® GOLD BASE INSTALLAZIONE PORTA-MONTAGE DE LA PORTE-COLOCACION DE LA PUERTA-MONTAGE DER TÜR-INSTALLATION DOOR

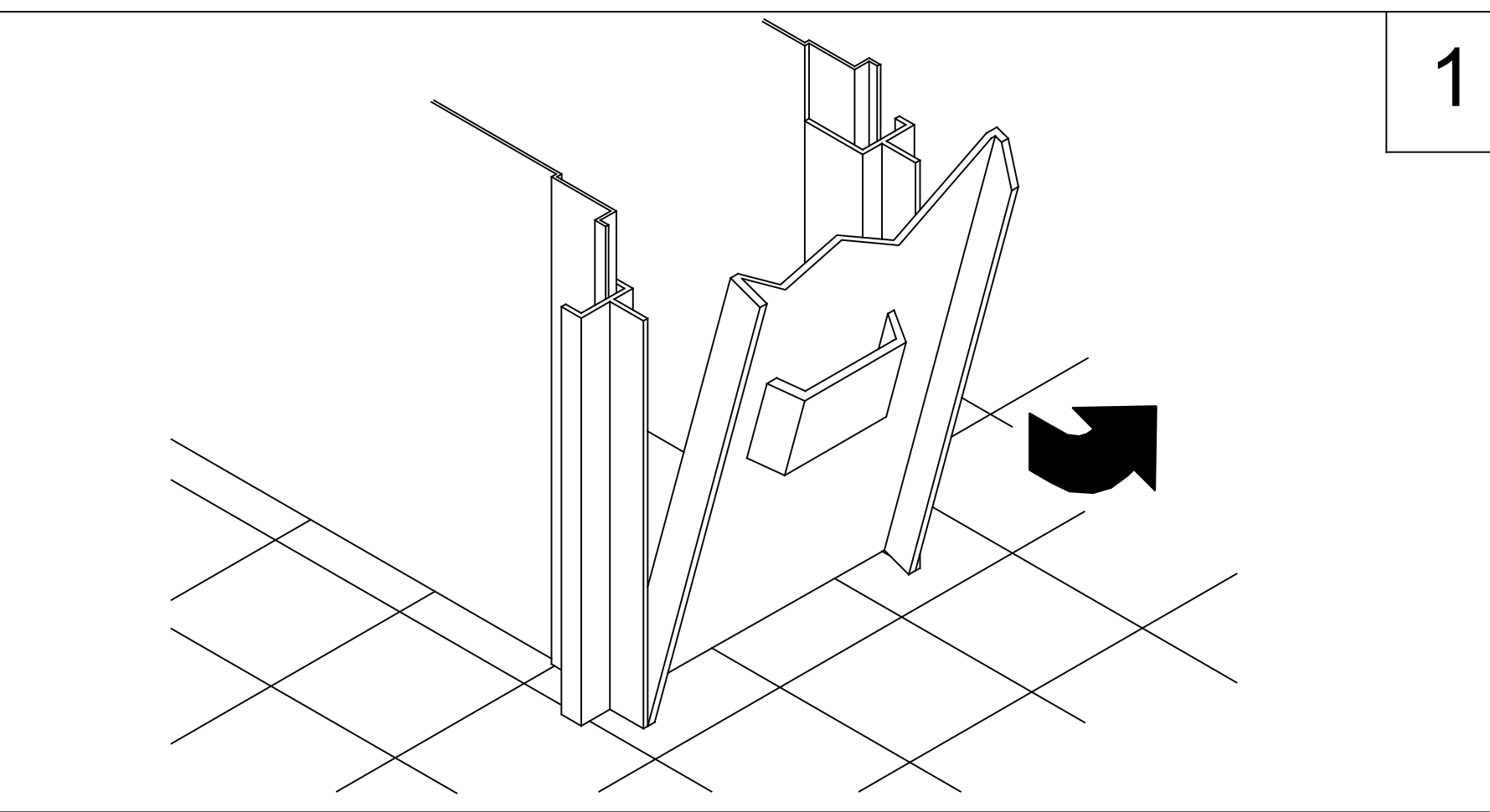

- IT** TOGLIERE LA MASCHERINA DI COPERTURA SOLO A MATURAZIONE AVVENUTA DELL'INTONACO. PULIRE ACCURATAMENTE L'INTERNO DEL CASSONETTO.
- FR** ENLEVER LA PLAQUE DE PROTECTION ET NETTOYER L'INTERIEUR DU CHASSIS.
- ES** QUITAR LA TAPA DE CIERRE DESPUES QUE HAYA FRAGUADO EL ENFOSCADO. LIPIAR CUIDOSAMENTE EL INTERIOR DEL ARMAZON.
- DE** DIE SCHUTZHÜLLE ERST NACH VOLLSTÄNDIGEM AUSTROCKNEN DES PUTZES ENTFERNEN UND KASTEN IM INNERN REINIGEN.
- EN** REMOVE FRAME COVER AND SPACER. CLEAN INTERNAL SPACE.

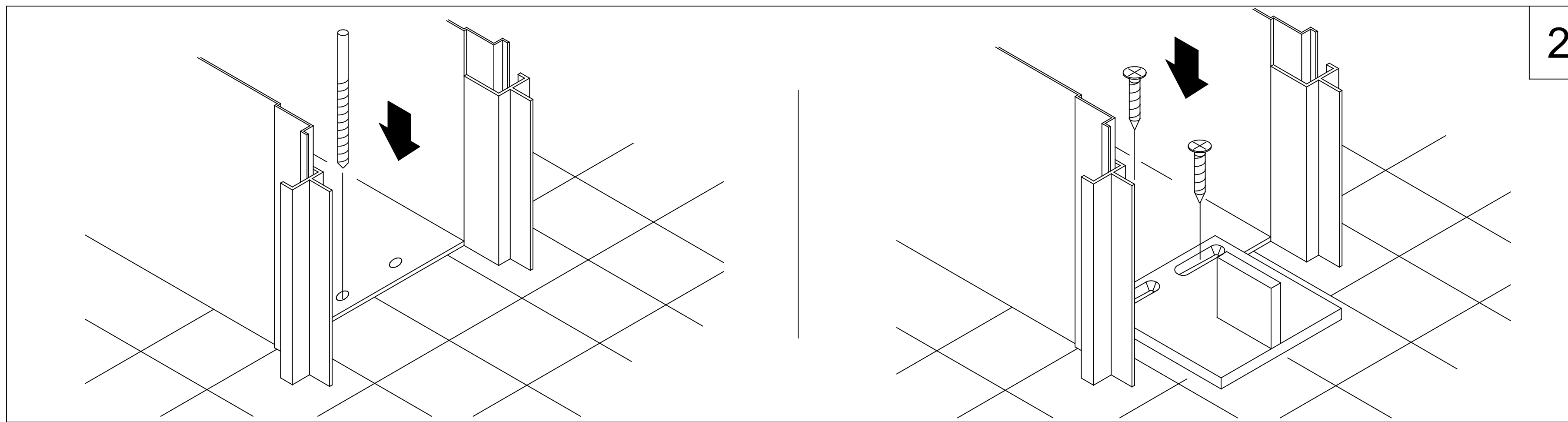

- IT** RIPASSARE I FORI DI FISSAGGIO DEL NASELLO DI GUIDA CON UNA PUNTA Ø3. FISSARE IL NASELLO DI GUIDA AI FORI PREDISPOSTI ALL'INTERNO DEL CASSONETTO UTILIZZANDO LE VITI IN DOTAZIONE. NEL CASO IL CASSONETTO SIA STATO MONTATO SOTTO IL LIVELLO DEL PAVIMENTO UTILIZZARE GLI SPESSORI IN DOTAZIONE.
- FR** PERCER AVEC UNE MECHE DE Ø3mm. LES TROUS DE FIXATION POUR PERMETRE LE LOGEMENT DES VIS. FIXER LE GUIDE EN UTILISANT LES TROUS A L'INTERIEUR DU CHASSIS, AVEC L'AIDE DES VIS FOURNIES.
- ES** REPASAR LOS TALADROS DE FIJACION DE LA PESTAÑA DE GUIA CON UNA BROCA DE Ø3mm., FIJAR LA PESTAÑA A LOS TALADROS PREVISTOS EN EL INTERIOR DEL ARMAZON UTILIZANDO LOS TORNILLOS EN DOTACION. EN EL CASO QUE EL ARMAZON HAYA SIDO MONTADO MAS BAJO DEL NIVEL DEL PAVIMENTO, UTILIZAR LOS SUPLEMENTOS EN DOTACION.
- DE** DIE VORGELOCHERTEN LÖCHER FÜR DIE TÜRFÜHRUNG MIT EINEM Ø3 BOHRER NOCHMAL DURCHLÖCHERN. DIE TÜRFÜHRUNG MITTELS DEN MITGELIEFERTEN SCHRAUBEN IM INNER DES KASTENS FIXIEREN. FALLS DER KASTEN UNTER DEM BODENNIVEAU MONTIERT WURDE, DIE FÜHRUNG MIT DEN MITGELIEFERTEN TEILEN AUSGLEICHEN.
- EN** DRILL PILOT HOLES FOR FIXING FLOOR GUIDE(Ø3). FIX FLOOR GUIDE IN THE CENTRE OF FRAME IN PRE-DRILLED HOLES USING FIXINGS PROVIDED.

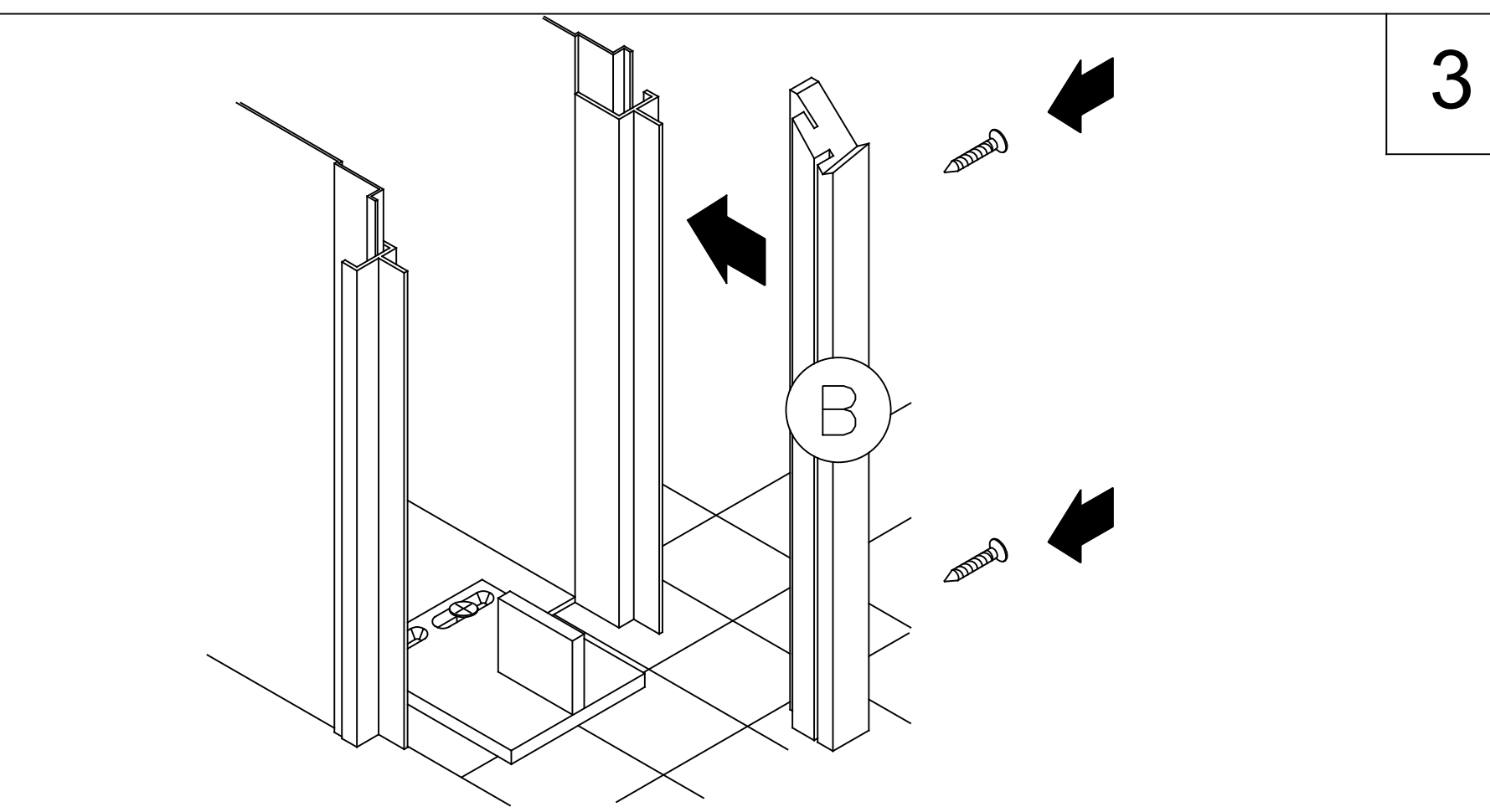

- IT** INCASTRARE UN MONTANTE (B) NELL'APPOSITA LAMELLA. FORARE MONTANTE E LAMIERA E FISSARE CON VITI AUTOFILETTANTI.
- FR** ENCASTRER UN MONTANT (B) DANS LA BORDURE VERTICALE DU CHASSIS ET LE FIXER AVEC DES VIS AUTOFOREUSES.
- ES** ENCAJAR UN MONTANTE (B) EN EL COSTADO DEL PREMARCO. TALADRAR MONTANTE Y COSTADO Y FIJAR CON TORNILLOS AUTORROSCANTES.
- DE** NUR EINEN DER (B) TÜRPFOSTEN IN DIE VORGESEHENE LAMELLE EINSpanNEN UND MIT SELBSTSCHNEIDENDEN SCHRAUBEN BEFESTIGEN. (DABEI TÜRPFOSTEN UND BLECH DURCHLÖCHERN).
- EN** FIT JAMB (B) ON THE BOX FRAME. IT IS HELPFUL TO DRILL THE METAL SHEET PREDEILL AND FIX WITH SCREWS.

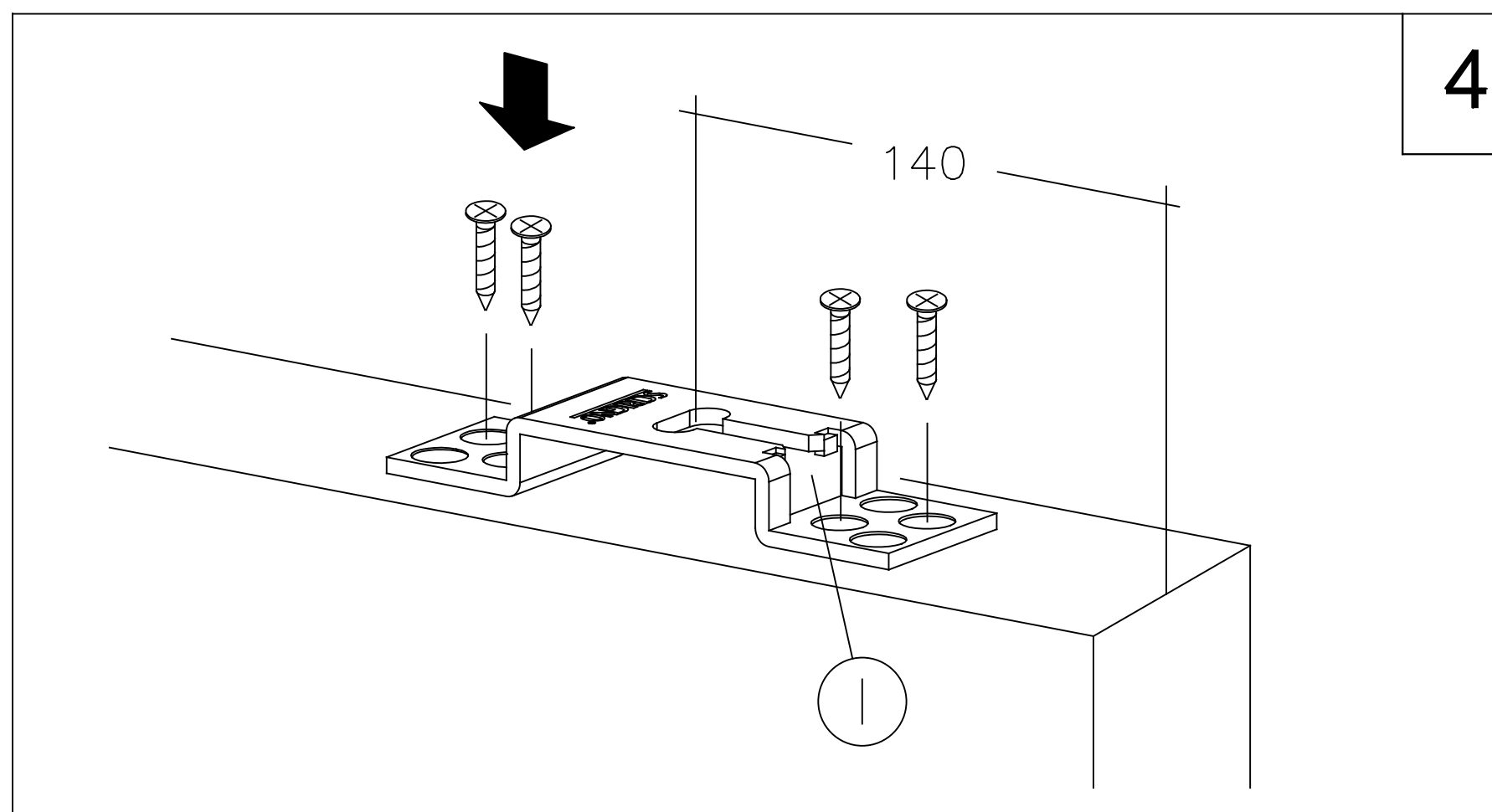

- IT** FISSARE LE STAFFE DI SOSPENSIONE ALLA PORTA TENENDO L'INCALVO(I) PER L'AGGANCIAMENTO DEL CARRELLO VERSO IL LATO ANTERIORE DELLA PORTA.
- FR** FIXER LES ETRIERS DE SUSPENSION SUR LA PORTE EN VEILLANT A CE QUE L'OUVERTURE (I) AMENAGEE POUR L'ACCROCHAGE DU CHARIOT SE TROUVE VERS LE COTE ANTERIEUR DE LA PORTE.
- ES** FIJAR LAS GARRAS DE SUJECION A LA PUERTA MANTENIENDO LA CAVIDAD(I) PARA LA FIJACION DEL CARRO ORIENTADA HACIA EL LADO DELANTERO DE LA PUERTA.
- DE** DIE AUFHÄNGEBÜGEL AN DER TÜR BEFESTIGEN; HIERBEI MUSS DIE ÖFFNUNG (I) FÜR DAS EINHAKEN DES ROLLWAGENS ZUR VORDERSEITE DER TÜR GERICHTET SEIN.
- EN** FIX SUSPENSION BRACKETS TO DOOR, WITH THE SLOT (I) FOR HOOKING ONTO HANGER TOWARDS FRONT SIDE OF DOOR

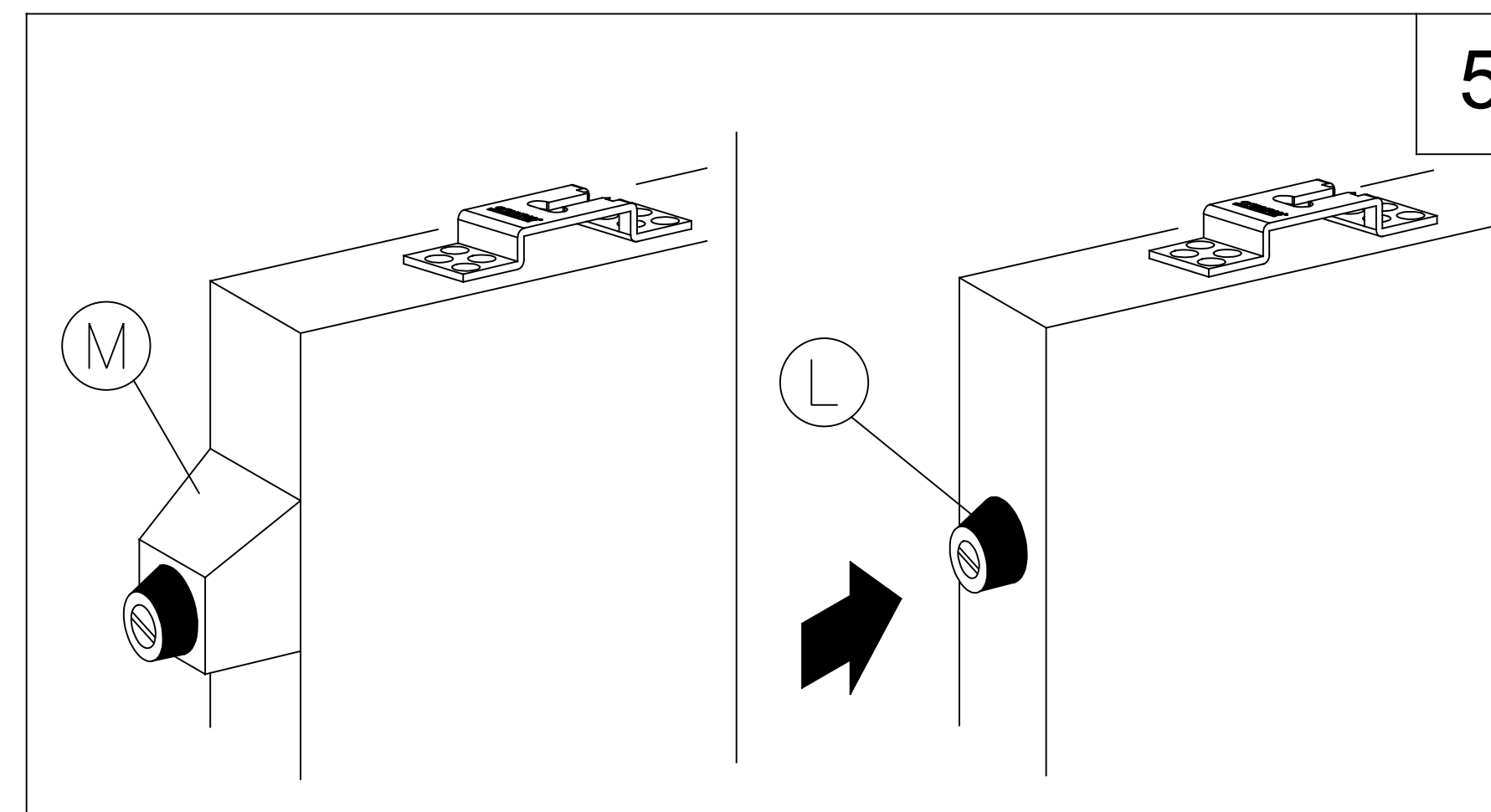

- IT** FISSARE I GOMMINI DI BATTUTA(L) SUL FIANCO POSTERIORE DELLA PORTA. PER LA SCOMPARSA PARZIALE INSERIRE UNO SPESSORE(M).
- FR** INSTALLER LES BUTEES(L) A L'ARRIERE DE LA PORTE. AFIN QUE LA PORTE DEPASSE, INSTALLER LES BUTEES SUR DES CALES EN BOIS(M).
- ES** FIJAR LOS TOPES(L) EN EL COSTADO POSTERIOR DE LA PUERTA, EN EL CASO DE INTRODUCCION PARCIAL, UTILIZAR UN SUPLEMENTO DE MADERA(M).
- DE** GUMMIPUFFER AUF DER HINTERSEITE DER TÜR MONTIEREN(L).SOLL DIE TÜR VORSTEHEN, HOLZKLOTZ ZWISCHEN TÜR UND GUMMIPUFFER MONTIEREN.
- EN** FIT THE RUBBER BUFFER(L) TO THE REAR OF EDGE OF THE PANEL,SHOULD YOU REQUIRE THE DOORS TO TOTALLY DISAPPEAR FIX BUFFER DIRECTLY TO THE DOOR, IF YOU WISH DOOR TO PROJECT SLIGHTLY FIX THE BUFFER TO APPLIED TIMBER SPACER.

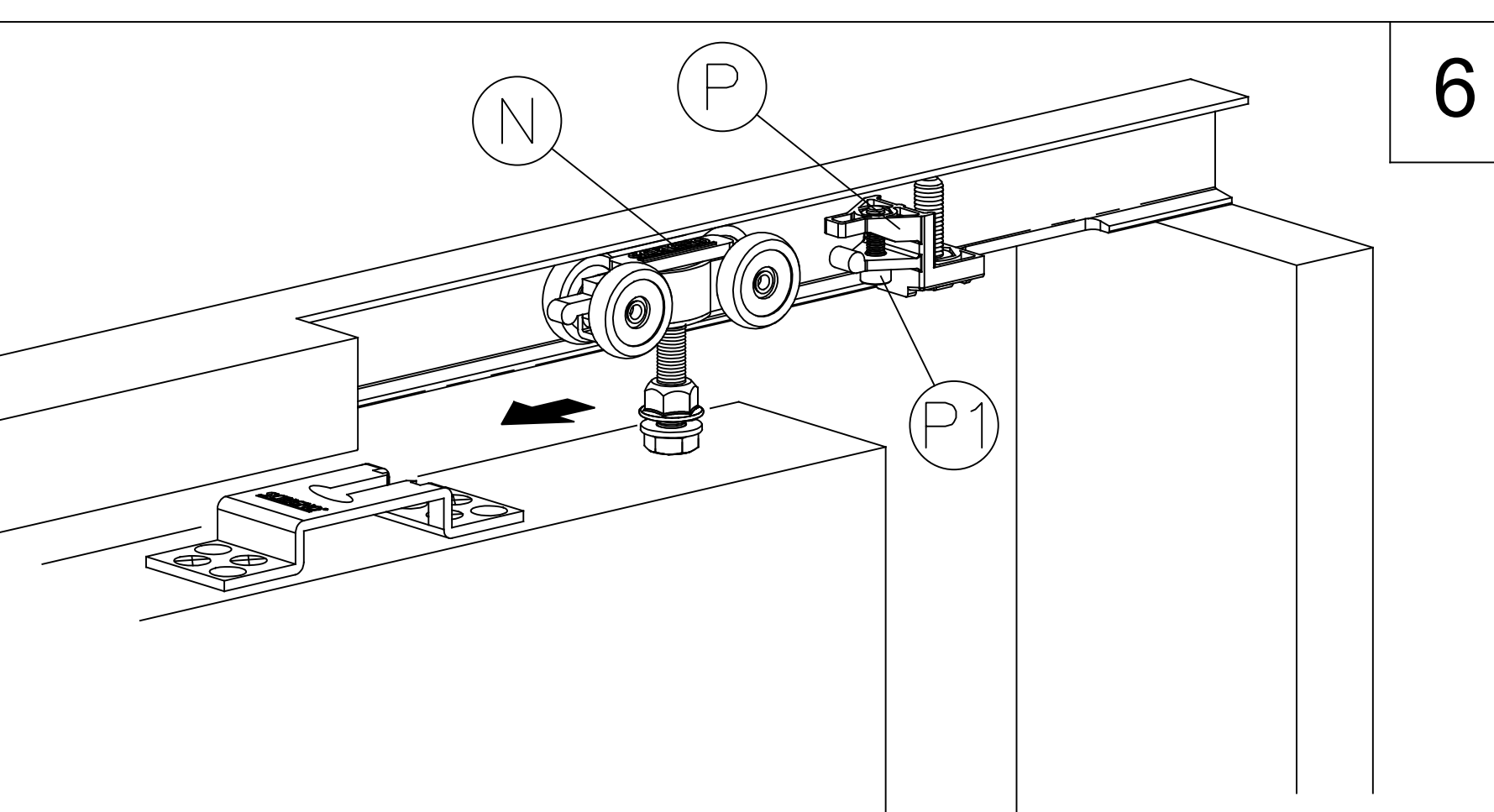

- IT** INTRODURRE I CARRELLI(N) E IL FERMO (P) NELL'APPOSITA ASOLA. AGGANCIARE LA PORTA E REGOLARE LO SCORRIMENTO. TRAMITE LA VITE(P1) REGOLARE L'AGGANCIAMENTO DELLA PORTA AL FERMO.
- FR** INTRODUIRE LES CHARIOTS (N) ET LA BUTEE (P) DANS LE LOGEMENT RESERVE. POSITIONNER LA PORTE ET EN REGLER LE COULISSEMENT. UTILISER LA VIS (P1) POUR REGLER LA FIXATION DE LA PORTE A LA BUTEE D'ARRET.
- ES** INTRODUCIR LOS CARROS (N) Y EL TOPE(P) EN EL OJAL PREDISPUETO PARA ALOJARLOS. ENCARZAR LA PUERTA Y REGULAR SU DESLIZAMIENTO. POR MEDIO DEL TORNILLO, (P1) AJUSTAR EL ENGANCHE DE LA PUERTA AL TOPE.
- DE** DEN ROLLWAGEN (N) UND DEN ANSCHLAG (P) IN DIE VORGESEHENE SCHIENE EINFÜGEN. DIE TÜR EINHAKEN UND DEREN GleITBEWEGUNG REGELN. ÜBER DIE SCHRAUBE (P1) DIE EINHAUNG DER TÜR AM ANSCHLAG REGELN.
- EN** FIT THE HANGERS (N) AND THE STOP (P) INTO THE SPECIFIC SLOT. HOOK ON THE DOOR AND ADJUST FOR CORRECT SLIDING MOVEMENT. USE SCREW (P1) TO ADJUST HOOKING OF DOOR TO STOP.

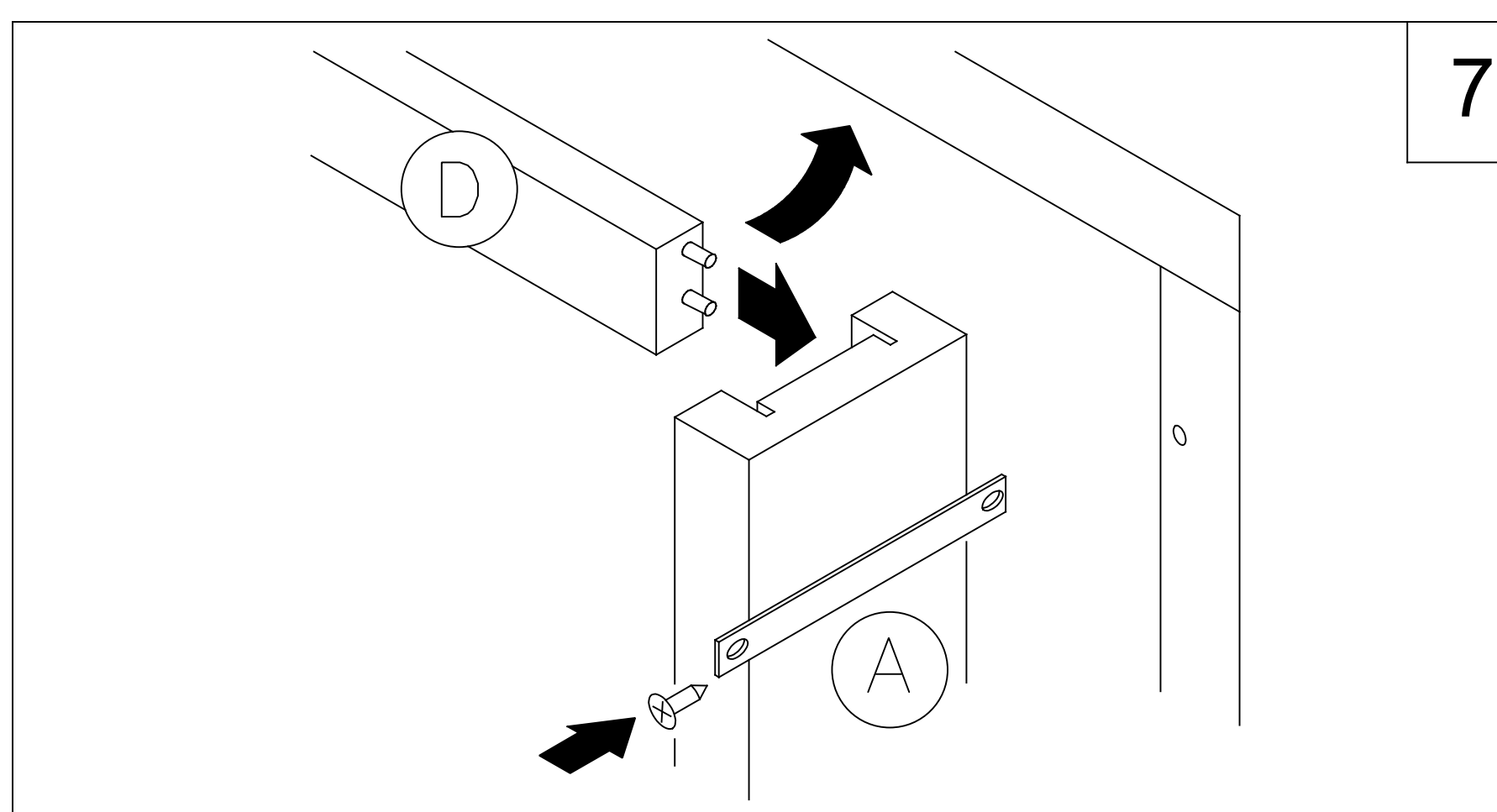



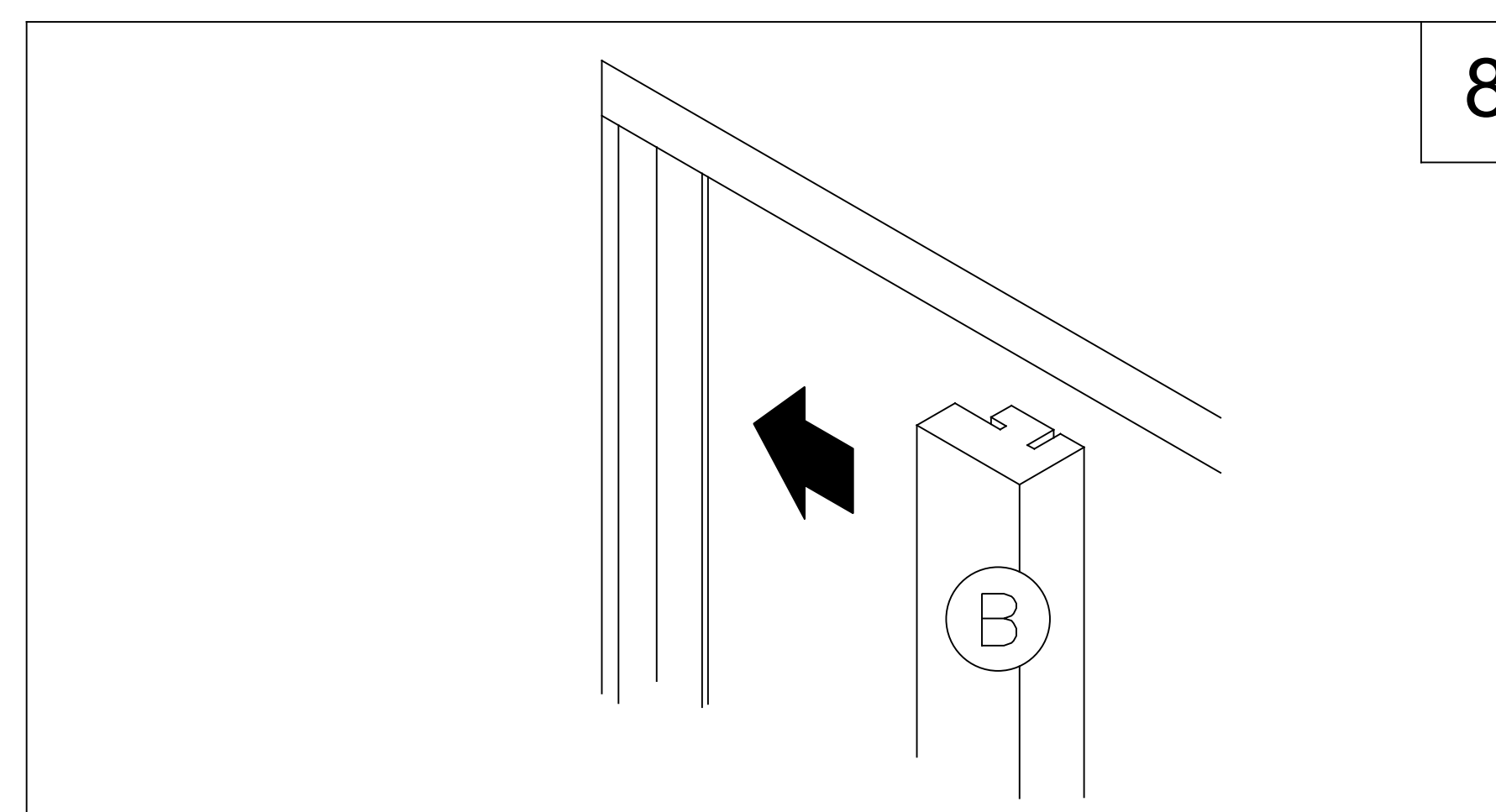

- IT** INSERIRE IL TRAVERSO (D) SUL MONTANTE (B) PRECEDENTEMENTE FISSATO, INCASTRARE IL MONTANTE DI BATTUTA(A) E FISSARLO IN POSIZIONE.
- FR** INTRODUIRE LA TRAVERSE (D) DANS LE MONTANT (B) DEJA INSTALLE, POSITIONNER LE MONTANT (A). FIXER LE MONTANT (A).
- ES** ENCAJAR EL TRAVERSAÑO (D) AL MONTANTE (B), FIJADO ANTERIORMENTE, COLOCAR EL MONTANTE DE CIERRE (A) Y FIJARLO.
- DE** QUERSTREBE (D) AN DEN SCHON BEFESTIGTEN TÜRPFOSTEN (B) UND GLEICHZEITIG DEN TÜRPFOSTEN (A) EINSpanNEN. DIESEN LOTRECHT AN DEN STÄNDER ANDÜBELN.
- EN** SLOT CROSS PIECE (D) TO JAMB (B) (ALREADY FITTED) AND AT THE SAME TIME SLOT IN JAMB (A).

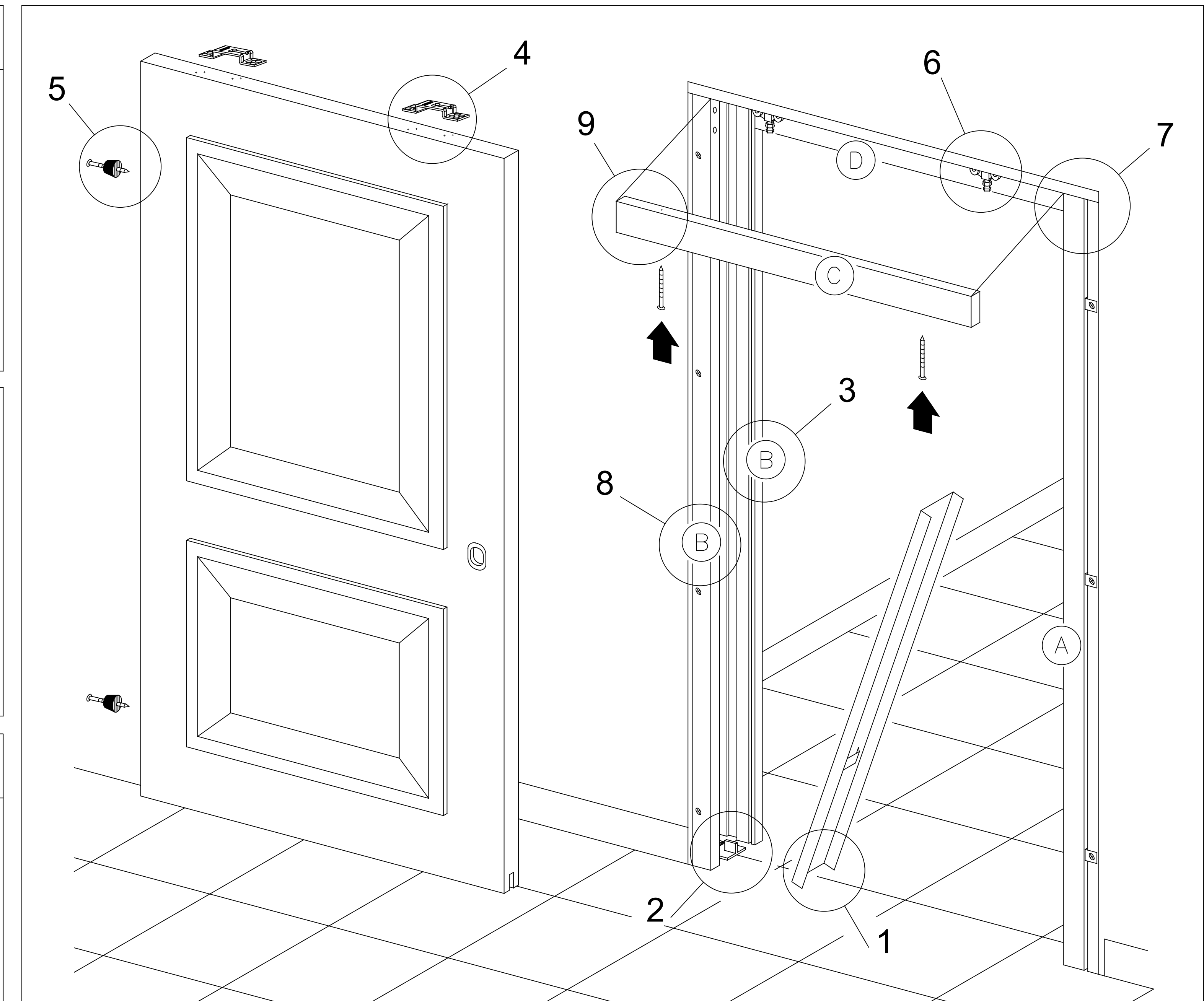

- IT** FISSARE IL SECONDO MONTANTE (B).
- FR** FIXER LE MONTANT (B) RESTANT.
- ES** FIJAR EL SEGUNDO MONTANTE (B).
- DE** DEN ANDEREN TÜRPFOSTEN (B) MONTIEREN.
- EN** FIT THE REMAINING JAMB (B).

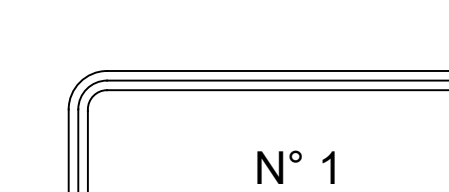
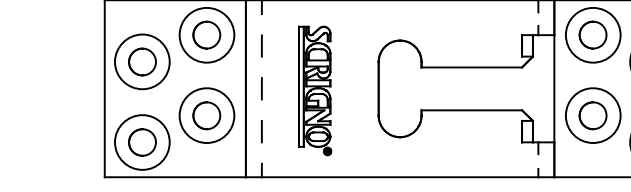

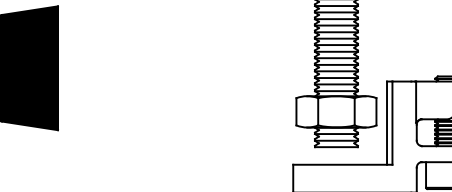
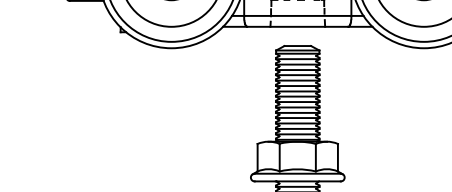
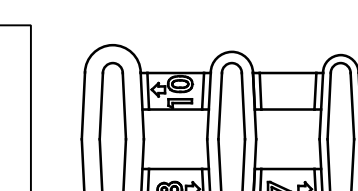
IN DOTAZIONE-EN DOTATION-EN DOTACION-ZUBEHOR-PACK CONTENTS

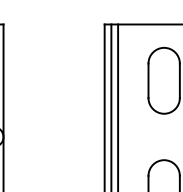
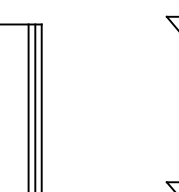
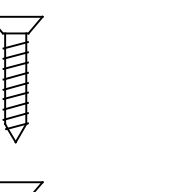
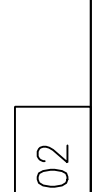
 N° 1
 N° 2
 N° 10
 N° 2
 N° 1
 N° 2
 N° 1 (Adattatore 10/8/7mm)
 N° 1
 N° 5
 N° 2
 N° 1
 N° 2

IT PORTATA MASSIMA DEL KIT CARRELLO Kg 120
FR CHARGE MAXIMALE DES CHARIOTS DE COULISSEMENT Kg 120
ES CAPACIDAD DE CARGA KIT CARRO Kg 120
DE TRAGFÄHIGKEIT DER ROLLWAGEN MAX. Kg 120
EN MAXIMUM DOORWEIGHT Kg 120

I dati pubblicati sono indicativi. SCRIGNO S.p.A. declina ogni responsabilità per le possibili inesattezze contenute, dovute ad errori di stampa, di trascrizione o per qualsiasi altro motivo e si riserva il diritto di apportare modifiche atte a migliorare i prodotti senza preavviso. La riproduzione anche parziale è severamente vietata a norme di legge.

Ces informations sont remises a titre indicatif. SCRIGNO S.p.A. declina toute responsabilité en cas d'erreur d'impression, de traduction, ou pour tout autre motif. Elle se réserve le droit d'apporter toute modification pour le montage et l'amélioration du produit sans preavis. Toute reproduction meme partielle de ce document est formellement interdite.

Los datos publicados son indicativos. La sociedad SCRIGNO S.p.A. declina toda responsabilidad por los posibles errores contenidos, debido a errores de imprenta, de transcripción o cualquier otro motivo y se reserva el derecho de mejorar los productos sin previo aviso. La reproducción total o parcial esta prohibida por la ley.

Bei den veröffentlichten Daten handelt es sich um Richtwerte. Die Scrigno S.p.A. lehnt jegliche Haftung für auf Druckfehler oder andere Ursachen zurückzuführende Ungenauigkeiten ab, und behält sich das Recht vor, jederzeit ohne Vorankündigung Verbesserungen am Produkt vorzunehmen. Der Nachdruck ist auch auszugweise gesetzlich untersagt.

The information given in this document is for descriptive purposes only. SCRIGNO S.p.A. will not be held responsible for any inaccuracies caused by printing errors, transcription errors or for any other reason, and reserves the right to make modifications, without giving prior notice, for the improvement of its products. The reproduction, including the partial reproduction, of this document is severely prohibited within the terms of the Law.

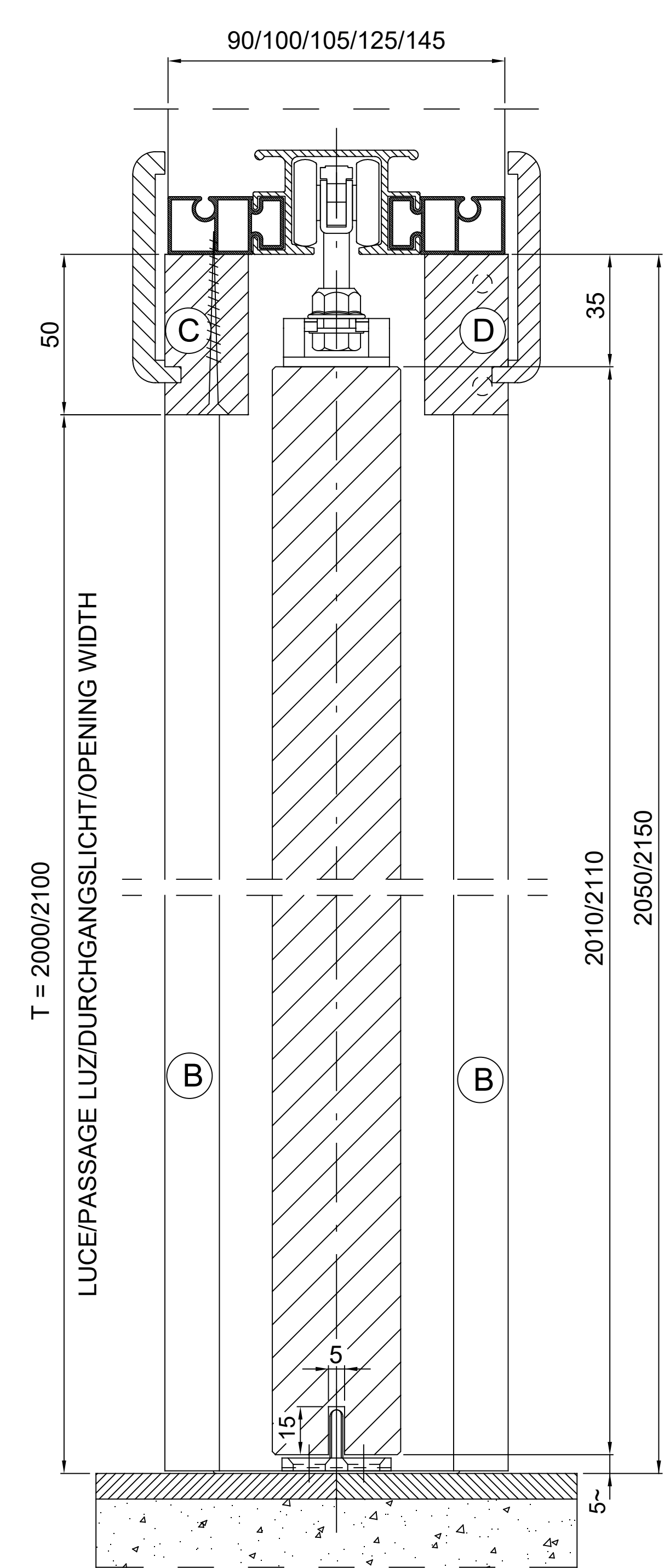
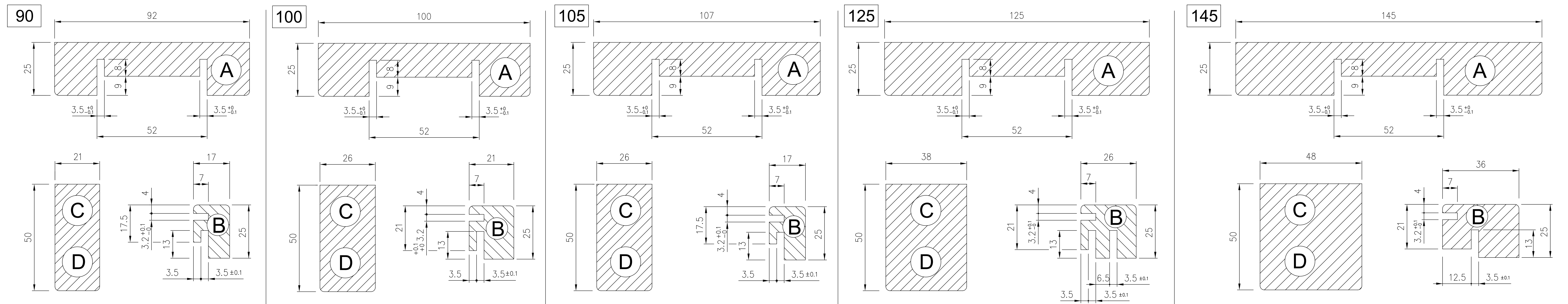

 Scrigno SpA | scrigno.net
 via Casale Sant'Ermete 975
 47822 Santarcangelo di Romagna (RN)
 ph. + 39 0541 757711
 fax + 39 0541 757780
 scrigno@scrigno.it

ANTE E STIPITI-PORTES ET KIT FINITION-PUERTAS Y MARCOS-TÜREN UND TÜRPFOSTEN-DOORS AND END POSTS

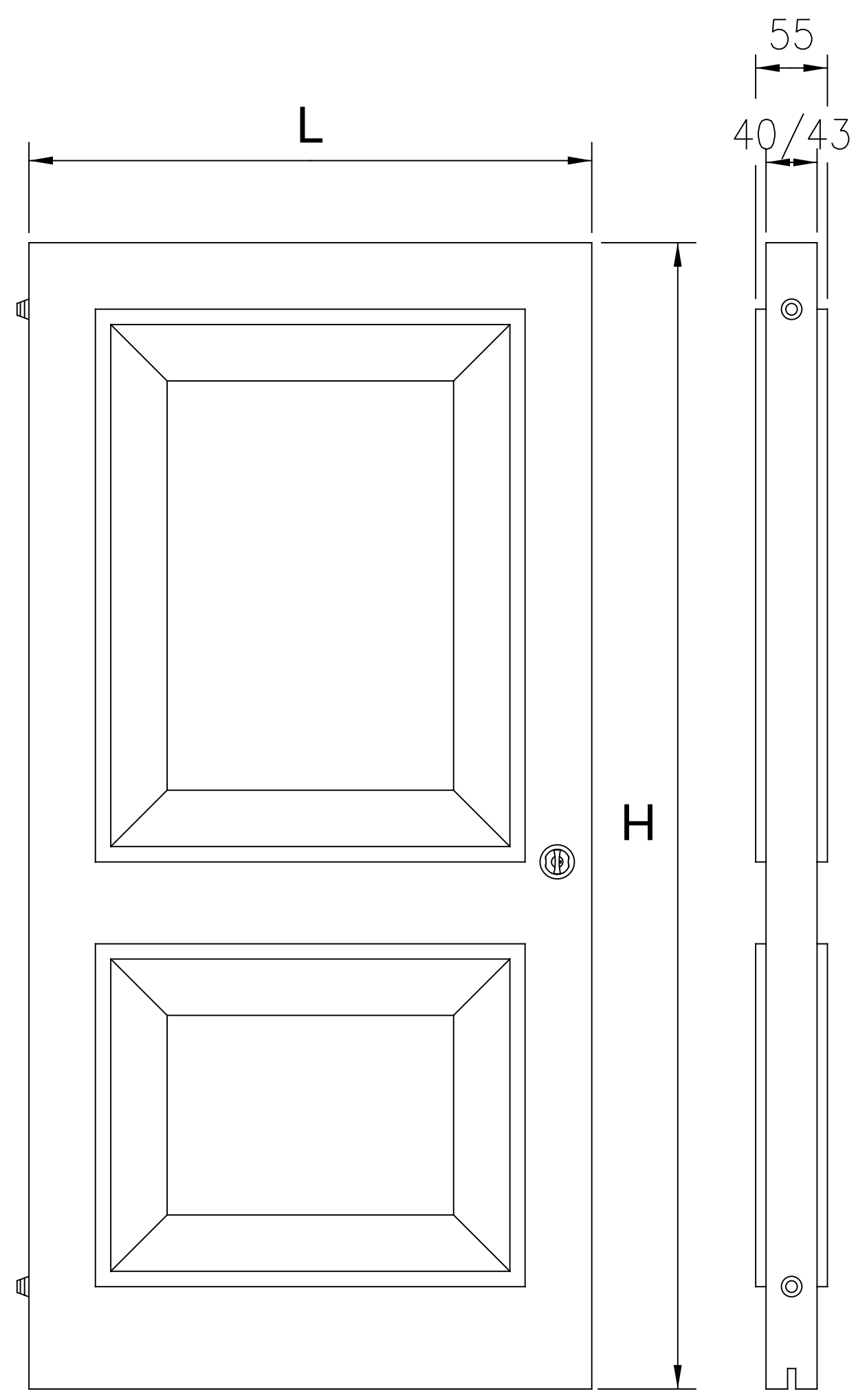

DIMENSIONI PANNELLO-DIMENSIONS DES PORTES-MEDIDAS HOJAS DE PUERTA-TÜRMASS-DOOR DIMENSIONS

| SINGOLO-SIMPLES-UNA HOJA-EINFLÜGELIG-SINGLE | | | |
|--|----|-------|--------------|
| P x T | N. | L x H | |
| 600x2000 600x2100 | 1 | 615 | 2010 2110 |
| 700x2000 700x2100 | 1 | 715 | 2010 2110 |
| 800x2000 800x2100 | 1 | 815 | 2010 2110 |
| 900x2000 900x2100 | 1 | 915 | 2010 2110 |
| 1000x2000 1000x2100 | 1 | 1015 | 2010 2110 |
| 1100x2000 1100x2100 | 1 | 1115 | 2010 2110 |
| 1200x2000 1200x2100 | 1 | 1215 | 2010 2110 |
| DOPPIO-DOUBLES-DOS HOJAS-ZWEIFLÜGELIG-DOUBLE | | | |
| P x T | N. | L x H | |
| 1200x2000 1200x2100 | 2 | 615 | 2010 2110 |
| 1400x2000 1400x2100 | 2 | 715 | 2010 2110 |
| 1600x2000 1600x2100 | 2 | 815 | 2010 2110 |
| 1800x2000 1800x2100 | 2 | 915 | 2010 2110 |
| 2000x2000 2000x2100 | 2 | 1015 | 2010 2110 |
| 2200x2000 2200x2100 | 2 | 1115 | 2010 2110 |
| 2400x2000 2400x2100 | 2 | 1215 | 2010 2110 |



SPESSORI PORTA - EPAISSEUR PORTE - GROSOR PUERTA TÜRSTÄRKE - DOOR THICKNESS

| | INTONACO ENDUIT ENFOSCADO PUTZ PLASTER | CARTONGESSO PLAQUE DE PLATRE CARTON YESO GIPSKARTON PLASTERBOARD | | | | |
|---|--|--|-----|-----|-----|-----|
| PARETE FINITA PAROIS FINIE PARED ACABADA FERTIGWANDSTÄRKE FINISHED WALL | 90 | 105 | 125 | 145 | 100 | 125 |
| INTERNO CASSONETTO LARGEUR INTERNE INTERIOR ARMAZON LEERRAUM INTERNAL OF FRAME | 54 | 69 | 89 | 89 | 54 | 69 |
| SPESS. MAX PORTA EPAISSEUR MAX. PORTE GROSOR MAXIMO PUERTA MAX.TÜR-STÄRKE MAX DOOR THICKNESS | 40 | 43 | 43 | 43 | 40 | 43 |
| SPESS. MAX BUGNE EPAISSEUR MAX. MOULDURES GROSOR MAXIMO MOLDURAS MAX. BREITE INKL.LEISTEN MAX OVERALL THICKNESS | - | 55 | 55 | 55 | - | 55 |

STIPITI-KIT FINITION-MARCOS-TÜRPFOSTEN-END POSTS

| SINGOLO-SIMPLES-UNA HOJA-EINFLÜGELIG-SINGLE | | | | | | | |
|--|----|----|--------------|----|------|----|------|
| P x T | A | B | C | | D | | mm |
| | N° | N° | N° | mm | N° | mm | |
| 600x2000 600x2100 | 1 | 2 | 2050 2150 | 1 | 595 | 1 | 595 |
| 700x2000 700x2100 | 1 | 2 | 2050 2150 | 1 | 695 | 1 | 695 |
| 800x2000 800x2100 | 1 | 2 | 2050 2150 | 1 | 795 | 1 | 795 |
| 900x2000 900x2100 | 1 | 2 | 2050 2150 | 1 | 895 | 1 | 895 |
| 1000x2000 1000x2100 | 1 | 2 | 2050 2150 | 1 | 995 | 1 | 995 |
| 1100x2000 1100x2100 | 1 | 2 | 2050 2150 | 1 | 1095 | 1 | 1095 |
| 1200x2000 1200x2100 | 1 | 2 | 2050 2150 | 1 | 1195 | 1 | 1195 |
| DOPPIO-DOUBLES-DOS HOJAS-ZWEIFLÜGELIG-DOUBLE | | | | | | | |
| P x T | A | B | C | | D | | mm |
| | N° | N° | N° | mm | N° | mm | |
| 1200x2000 1200x2100 | - | 4 | 2050 2150 | 1 | 1200 | 1 | 1200 |
| 1400x2000 1400x2100 | - | 4 | 2050 2150 | 1 | 1400 | 1 | 1400 |
| 1600x2000 1600x2100 | - | 4 | 2050 2150 | 1 | 1600 | 1 | 1600 |
| 1800x2000 1800x2100 | - | 4 | 2050 2150 | 1 | 1800 | 1 | 1800 |
| 2000x2000 2000x2100 | - | 4 | 2050 2150 | 1 | 2000 | 1 | 2000 |
| 2200x2000 2200x2100 | - | 4 | 2050 2150 | 1 | 2200 | 1 | 2200 |
| 2400x2000 2400x2100 | - | 4 | 2050 2150 | 1 | 2400 | 1 | 2400 |

CARTONGESSO - PLAQUE DE PLATRE - CARTON YESO - GIPSKARTON - PLASTERBOARD

INTONACO - ENDUIT - ENFOSCADO - PUTZ - PLASTER

